

E100H Series

Diameter ϕ 100mm Hollow shaft type Incremental Rotary encoder

■ Features

- Great environmental resistance
- High stability of output
- Specially using in Elevator

 Please read "Caution for your safety" in operation manual before using.



■ Ordering information

E100H	35	10000	6	2	5
Series	Shaft diameter	Pulse/1Revolution	Output phase	Output	Power supply
Diameter ϕ 100mm Hollow shaft type	ϕ 35mm	512 1024 10000	3 : A, B, Z 6 : A, \bar{A} , B, \bar{B} , Z, \bar{Z}	T : Totem pole output N : NPN open collector output V : Voltage output L : Line driver output(※)	5 : 5VDC \pm 5% 24: 12-24VDC \pm 5%

※The power of Line driver is only for 5VDC

■ Specifications

Item	Diameter ϕ 100mm Hollow shaft type of Incremental rotary encoder		
Resolution(P/R)	(Note1) 512, 1024, 10000		
Electrical specification	Output phase	A, B, Z phase (Line driver output A, \bar{A} , B, \bar{B} , Z, \bar{Z} phase)	
	Phase difference of output	Phase difference between A and B : $\frac{T}{4} \pm \frac{T}{8}$ (T=1cycle of A phase)	
	Control output	Totem pole output	• Low \Rightarrow Load current:Max. 30mA, Residual voltage : Max. 0.4VDC • High \Rightarrow Load current:Max. 10mA, Output voltage(Power supply 5VDC):Min. (Power supply-2.0)VDC, Output voltage(Power supply 12-24VDC):Min. (Power supply-3.0)VDC
		NPN open collector output	Load current : Max. 30mA, Residual voltage : Max. 0.4VDC
		Voltage output	Load current : Max. 10mA, Residual voltage : Max. 0.4VDC
		Line driver output	• Low \Rightarrow Load current : Max. 20mA, Residual : Max. 0.5VDC • High \Rightarrow Load current : Max. -20mA, Output voltage : Min. 2.5VDC
	Response time (Rise/Fall)	Totem pole output	Max. 1 μ s
		NPN open collector output	Max. 1 μ s
		Voltage output	Max. 1 μ s
		Line driver output	Max. 0.5 μ s
	Max. Response frequency	300kHz	
	Power supply	• 5VDC \pm 5% (Ripple P-P:Max. 5%) • 12-24VDC \pm 5% (Ripple P-P:Max. 5%)	
	Current consumption	Max. 80mA (disconnection of the load), Line driver output:Max. 50mA (disconnection of the load)	
	Insulation resistance	Min. 100M Ω (at 500VDC mega between all terminals and case)	
Dielectric strength	750VAC 50/60Hz for 1 minute (Between all terminals and case)		
Connection	Cable outgoing type		
Mechanical specification	Starting torque	Max. 300gf \cdot cm (0.03N \cdot m)	
	Rotor inertia.	Max. 800g \cdot cm ² (8 \times 10 ⁻⁵ kg \cdot m ²)	
	Shaft loading	Radial : 5kgf, Thrust : 2.5kgf	
	Max. allowable revolution	(Note2) 3600rpm	
Vibration	1.5mm amplitude at frequency of 10 ~ 55Hz in each of X, Y, Z directions for 2 hours		
Shock	Max. 75G		
Ambient temperature	-10 ~ 70 $^{\circ}$ C (at non-freezing status), Storage:-25 ~ 85 $^{\circ}$ C		
Ambient humidity	35~85%RH, Storage:35~90%RH		
Protection	IP50 (IEC standard)		
Cable	ϕ 5mm, 5P, Length:5m, Shield cable (Line driver output: ϕ 6mm, 8P)		
Accessory	Spring bracket 2EA		
Unit weight	Approx. 1200g		
Approval	CE (Except for Line driver output)		

※(★Note1)Not indicated type is customizable.

※(★Note2)Max. allowable revolution \geq Max. response revolution 【Max. response revolution(rpm) = $\frac{\text{Max. response frequency}}{\text{Resolution}} \times 60 \text{ sec}$ 】

Incremental ϕ 100mm Hollow Shaft Type

Control output diagram

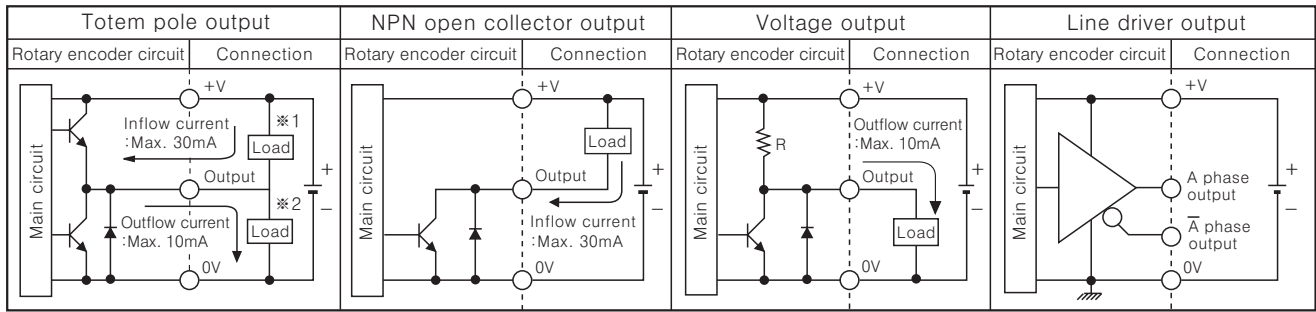

⇒ Totem pole output type can be used for NPN open collector output type(*1) or Voltage output type(*2).
 ⇒ All output circuits of A, B, Z phase is same. (Line driver output is for A, \bar{A} , B, \bar{B} , Z, \bar{Z})

Connections

● Totem pole output / NPN open collector output / Voltage output

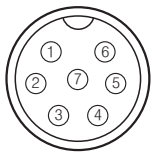

SCN-16-7P

Pin No.	Function	Cable color
①	+V	Brown
②	GND	Blue
③	OUT A	Black
④	OUT B	White
⑤	OUT Z	Orange
⑥	F.G	Shield
⑦	N.C	N.C

※ Unused wires must be insulated.
 ※ The metal case and shield cable should be grounded(F.G).

● Line driver output

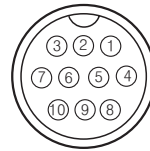

SCN-20-10P

Pin No.	Function	Cable color
①	+V	Brown
②	GND	Blue
③	OUT A	Black
④	OUT \bar{A}	Red
⑤	F.G	Shield
⑥	OUT B	White
⑦	OUT \bar{B}	Gray
⑧	OUT Z	Orange
⑨	OUT \bar{Z}	Yellow
⑩	N.C	N.C

※ N.C(Not Connected)

Output waveform

● Totem pole output / NPN open collector output / Voltage output

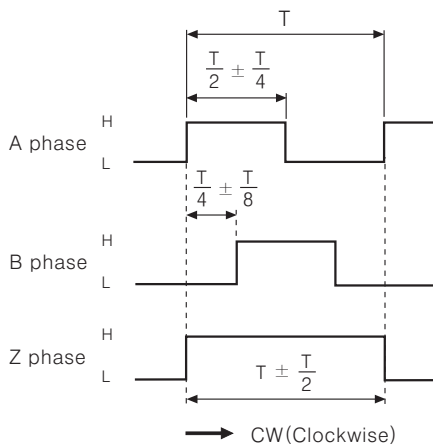

※ CW : As viewed from the shaft

● Line driver output

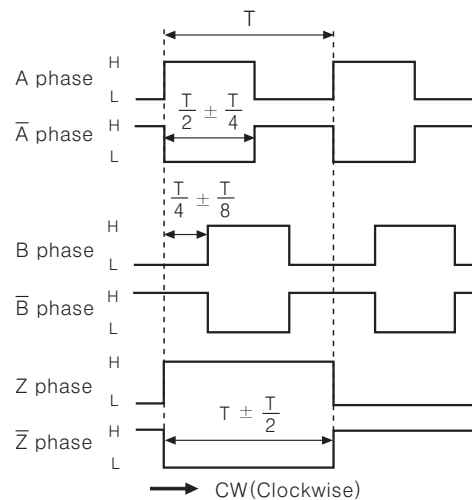

- (A) Counter
- (B) Timer
- (C) Temp. controller
- (D) Power controller
- (E) Panel meter
- (F) Tacho/Speed/Pulse meter
- (G) Display unit
- (H) Sensor controller
- (I) Switching power supply
- (J) Proximity sensor
- (K) Photo electric sensor
- (L) Pressure sensor
- (M) Rotary encoder
- (N) Stepping motor & Driver & Controller
- (O) Graphic panel
- (P) Field network device
- (Q) Production stoppage models & replacement

E100H Series

Dimensions

(Unit:mm)

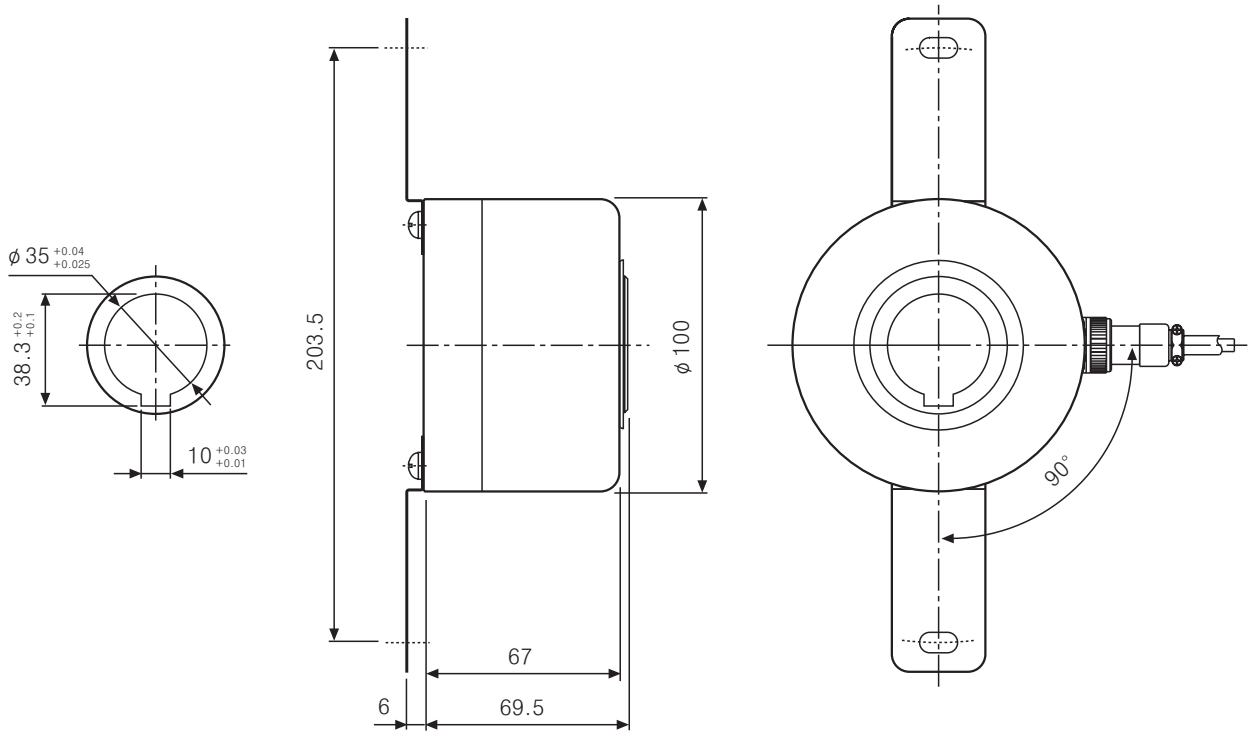

Connector cable

- Totem pole output / NPN open collector output / Voltage output

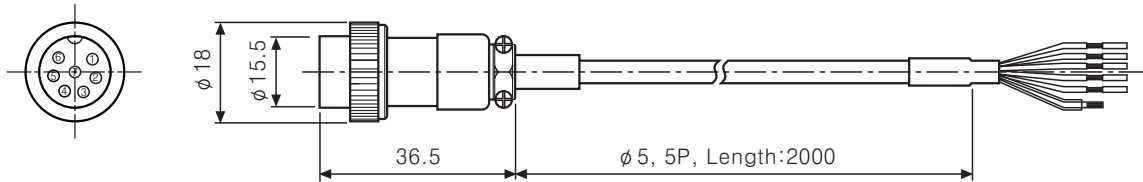

- Line driver output

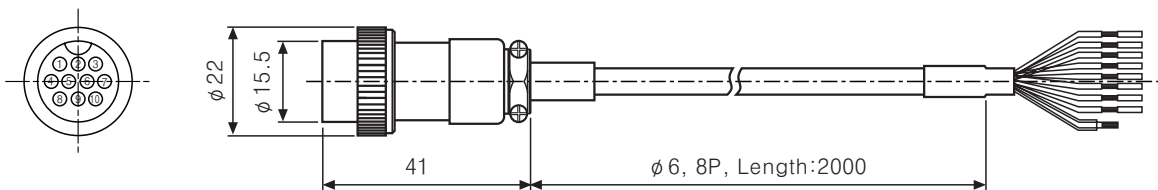

※10m Connector cable is customizable.

※Cable outgoing type is customizable.

- Bracket

